



INDUSTRIAL HIGH-SPEED AUTOMATIC FOLD-UP DOORS

DESCRIPTION

High-speed fold-up doors are an innovative solution to save energy and space. With fast opening and closing speed, this type of door improves efficiency in the working environment, in particular where a large size opening is needed. Equipped with the best components of the market, they provide a high grade of reliability for a perfect return on investment. Fold-up doors structure is made of zinc-plated steel or AISI 304 stainless steel. It can be painted in any RAL colour. Strong horizontal bars reinforce the flexible curtain, in order to make the door resistant to wind. Side guides even include nylon brushes to minimize air flow through the door. The polyester curtain can be personalized with the Customer's logo or by adding transparent sections that improve traffic visibility. The mechanism rolls and vertically lifts up the curtain. We offer a wide range of opening commands, devices and accessories.



ADVANTAGES

The installation of fold-up doors is the ideal investment choice for commercial and industrial spaces. They ensure easy and quick access to areas. These doors can be used either inside or outside, since the required space is reduced to the minimum. The strong construction allows the doors to be installed outside without fearing wind. The wind load resistance class for internal doors is Class 1, while for external environments it can be Class 2, 3, 4 and even 5, since the capacity to withstand the wind is higher. Furthermore, with high speed doors it is easier to control the variation of temperature of the area, thanks to their speed in opening and closing. Consequently, heating and cooling energy consumption is reduced. The structure is strong and durable, so doors turn out to be almost maintenance-free. In fact, high-speed folding doors are designed for an intensive everyday use in high activity access areas. This type of door ensures a reduction of noise and an elimination of dust coming from the nearby working areas. Spare parts and accessories are available.

APPLICATIONS



LOGISTICS

- Designed for high traffic flows
- High speed of opening and closing
- Safe for workers and for vehicles
- For every kind of environment
- High reliability with low maintenance
- Small dimensions to fit everywhere
- Wide range of opening devices
- High grade of customization available



BIG DIMENSIONS

- Maximum width and/or height
- Strong steel framework
- Reinforced flexible curtain
- Improved wind resistance
- Wide lateral runners
- Geared motor with high torque
- Anemometer (optional)



ROLLING CONVEYORS / MACHINERY PROTECTION

- Essential and cost-effective
- Short curtain for conveyor passage
- Special fixings and support framework
- Lever switches to confirm position
- Photocells for industrial environment
- Clean contacts for limit positions
- Protection against UV rays (option)



OVERHEAD CRANE

- Big dimensions from floor to the top compatible with overhead crane
- Special lateral runners with passage
- Improved insulation against noise and dust
- Commanded by overhead crane
- Wide range of available options

TECHNICAL SPECIFICATIONS

Our high-speed door structure is self-bearing, made of zinc-plated steel or, if asked, even of AISI 304 stainless steel. It can be painted in any RAL colour. The structure includes both a frontal crankcase that covers the curtain when it goes up and a cover for the operating system (geared motor and limit switch), so that the engine is protected from dust and rain. Horizontal windbars reinforce the flexible panel. Side guides are equipped with brushes of soft nylon so that insulation from dust and noise is improved. The door PVC curtain is fire-retardant and fully customizable. Furthermore, to the curtain you can add transparent sections in order to guarantee visibility and security. The engine adopted is a three-phase self-braking geared motor with heavy duty cycle and a rotating limit switch on it. It is an industrial motor with self ventilation and aluminium wings for cooling system. The motor is designed to be robust, so its utilisation cycle is S1 100% 24/24 h. Motor and gear motor are of a unified type.

Supply voltage	400 Vac ⁽¹⁾
Supply type	Three-phases
Supply frequency	50 Hz
Control panel	Automatic
Motor type	Asynchronous
Motor duty cycle	S1 100 %
Gearbox type	Worm
Wind load resistance	Up to class 5

Maximum width	15 m
Maximum height	10 m
Maximum area	100 m ²
Opening speed	Up to 0.8 m/s or more
Limit switch	Mechanical
Panel type	Flexible
Framework	Metallic
Cycles	1.000.000

(1) Supply 230 Vac single-phase or three-phases on request.



COMPONENTS

All different parts of the upper framework and lateral runners are pre-assembled in order to reduce installation time.



FLEXIBLE PANEL

	RAL 1015 Ivory		RAL 5002 Blue		RAL 8017 Brown
	RAL 1021 Yellow		RAL 5012 Light Blue		RAL 9005 Black
	RAL 2004 Orange		RAL 6026 Green		RAL 9016 White
	RAL 3002 Red		RAL 7038 Grey		

- Made of polyester fabric coated with PVC
- Fabric: 1100 dtex
- Traction resistance: 3000 N / 50 mm (warp and weft)
- Tear strength: 400 N (warp and weft)
- Fire-extinguishing class B, according to rule EN 13501-1
- Transparent portholes for pedestrians and vehicles visibility
- Mesh sections for air permeability
- Special version for food industry
- Antistatic version for special uses
- Can be printed with the company logo, slogan or image



ANTI-UV PVC CURTAIN

- Waterproof protection against UV radiation
- PVC material
- For use in welding areas
- Colour: red
- Complies with DIN EN ISO 25980



STANDARD CURTAIN

- Weight in roll: 900 gr/sqm
- Thickness: 0.8 mm approx
- High stability to UV rays
- Wide range of available colours



INSULATED CURTAIN

- Weight: 1300 gr/sqm
- Thickness: 4 mm approx
- Sponge layer on one side
- Thermal and acoustic insulation
- Available colours: grey, white and blue

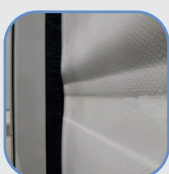

DOUBLE INSULATED CURTAIN

- Thickness: 5 mm approx
- High mechanical resistance
- Sponge layer between two panels of 900 gr/sqm each
- Available colours: grey, white and blue



DOUBLE PVC CURTAIN

- Weight in roll: 1800 gr/mqs
- Thickness: 1.6 mm approx
- Wide range of available colours



TRANSPARENT SECTIONS

The curtain can be made with one or more transparent sections that provide visibility to pedestrians and vehicles.

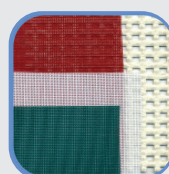

MESH SECTIONS

To allow the air to flow through the door, it is possible to realize some mesh sections on the curtain. Several colours and dimensions are available.

TRANSPARENT SECTIONS

The flexible curtain can be realized with one or more transparent sections, depending on the Customer needs. They increase the workers safety by making possible to watch on the other side of the door and besides they allow the natural light to come in the building from outside to improve comfort too. Below there are some configurations but any other can be evaluated by our technical department.

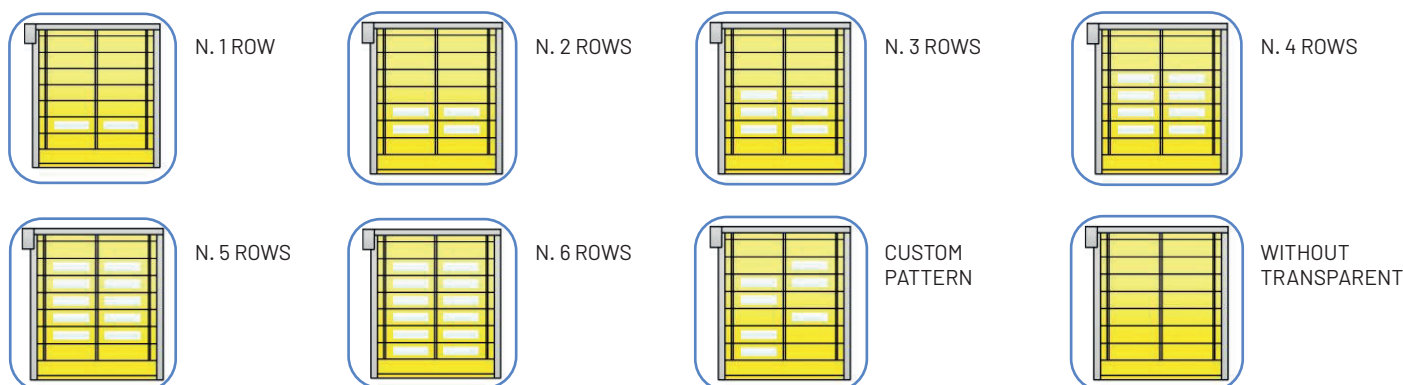

NOTE: the number of columns of portholes depends on the width of the door and cannot be changed.

ELECTRICAL BOARDS

T 500/7

- Supply voltage 400 Vac 50 Hz three-phases
- Microprocessor controlled
- Power card separated from logic card
- Power relays mounted on DIN rail
- Thermal relay for motor protection
- Status LEDs for easy diagnostic
- Supply main switch on front panel
- Supply fuses on main switch
- Emergency button on front panel
- Start cycle button on front panel
- Different settable functions
- Large space for additional devices
- In accordance with EN 13241
- Plastic box IP56
- Stainless steel version available
- Dimensions: 300 x 380 x 130 mm
- Weight: 5 kg

Limit switch: mechanical

OPTIONS

- Metal case
- Stainless steel case
- Transparent front cover
- Cycle counter display



T500/7 WITH INVERTER

- Supply voltage 230 Vac 50 Hz single-phase
- Microprocessor controlled
- Power relays mounted on DIN rail
- Thermal relay for motor protection
- Status LEDs for easy diagnostic
- Supply main switch on front panel
- Supply fuses on main switch
- Emergency button on front panel
- Start cycle button on front panel
- Different settable functions
- Widely settable industrial inverter
- Large space for additional devices in accordance with EN13241
- Plastic box IP65
- Dimensions: 300 x 380 x 190 mm
- L.S. mod. weight: 5 kg
- A.B. mod. weight: 7 kg

Limit switch: mechanical

OPTIONS

- Metal case
- Stainless steel case
- Transparent front cover
- Cycle counter display



OPENING DEVICES*



REMOTE CONTROL

Transmitters hand-held or mounted on vehicles control one or more doors by communicating to receivers inside the control panel.



RADAR OCM20

Sensor with microwave technology that detects movements and opens the door. Sensitivity, direction and other options can be set.



RADAR BEA FALCON

Microwave sensor provided with advanced functions such as filtering pedestrians and vehicles. Settable from ground with remote controller.



RADAR BEA CONDOR

Combination of the microwave technology with an active infrared sensor, allowing it to detect both movement and presence.



METAL DETECTOR

A magnetic sensor inside the control panel detects metallic objects by means of one or more loops under the floor, then opens the door.



PHOTOCELL

Usually used as a safety device, it can also be used as an opening device when placed somewhere in front of the door.



PUSH BUTTON

A simple push button controls the opening. In some cases, a pedestrian push button could be useful to partially open the door. Some options are available at an extra charge:

- "Mushroom" push-button
- Double push-button
- Triple push-button
- "Magic switch" touchless opening button



PULL SWITCH

A simple rope coming down from the top that, if pulled, opens the door. Made of zinc-plated steel with high mechanical resistance.



BADGE READER

Access control by means of plastic badges with credit card dimensions. Each badge can be added or removed independently.



* Photos are for reference only, as the devices may differ in appearance but have the same features.

| SAFETY DEVICES*



SAFETY PHOTOCELL

Directly placed on the framework, it detects objects between the transmitter and the receiver and immediately disables the automatic closure of the door.

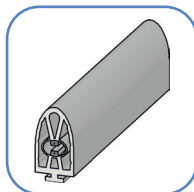

SAFETY EDGE

A soft rubber edge inside the bottom bar of the flexible curtain is sensible to pressure and re-opens the door if it touches an obstacle.



WIRELESS BRIDGE

The connection between the control panel and the safety edge is provided by a safety radio bridge to avoid failures while the door is moving.



SAFETY LIGHT CURTAIN

A series of infrared rays covers the height of the door preventing anybody to get in contact with the curtain when the door is closing.

Other safety devices can be provided on request, please contact our technical department for further information.

| EMERGENCY OPENING*



Manual emergency opening with a hexagonal key



UPS system to operate the door in case of power failure (available at an extra charge)

| ACCESSORIES*



Traffic light for industrial use:

- Supply: 12/24 Vdc
- Red LED light
- Green LED light



Buzzer



Column guard:

- \varnothing 102 mm tube-shaped
- Thickness: 5 mm
- Height: 1000 mm
- \varnothing 200 mm circular base plate included
- 1023 Yellow RAL colour with black diagonal stripes

Interlocking with other doors is possible.

* Photos are for reference only, as the devices may differ in appearance but have the same features.

EUROPEAN STANDARD



The European standard EN 13241, known as "Standard for industrial, commercial and garage doors and gates", has been established in May 1st 2005. The standard covers all aspects of the door: mechanical, electrical and functional. This standard is the reference for any manufacturer of doors around the world.

During the design of our products we keep door safety in mind to avoid any risk for workers. First of all we include a reversing mechanism that senses an obstruction and reverses closing door back to the open position. This system helps to minimize the consequence of a downward impact, making the door safe also for pedestrians. All our doors have been submitted to a strict "Initial Type Test" carried out by the manufacturer under the control of an organism recorded at the Italian Ministry of Enterprise and Made in Italy.



Only after a positive result in the evaluation of conformity we have been able to obtain the CE declaration document and therefore the CE marking. With over 70 years of experience in the branch of industrial doors, we strive every day for continuous improvement of our products and systems in order to give Customers the highest grade of safety and reliability.



MODEL 180

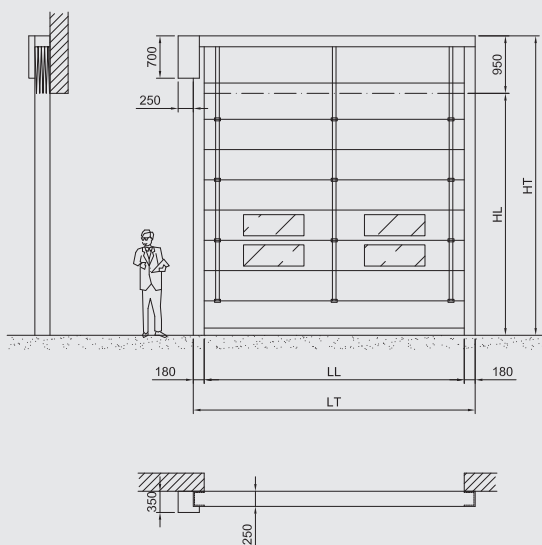

MODEL 260

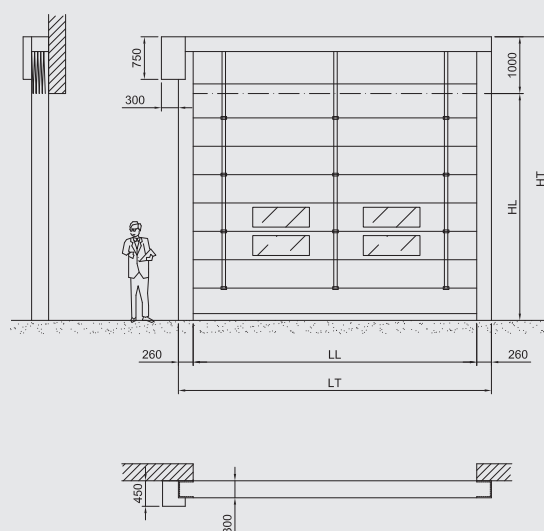

MODEL 320

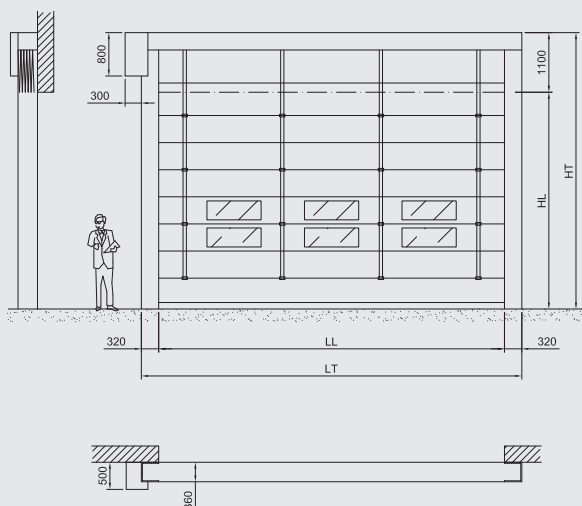

LEGEND

- LL: clear opening width
- LT: framework width
- HL: clear opening height
- HT: framework height

Lateral runners and upper framework dimensions depend on door dimensions. The drawings in this page have to be considered as reference only, please contact our technical department for further information.

* approx. dimensions considering maintenance.

The geared motor can be laterally mounted on the right or on the left side (as standard) or frontally mounted (optional).



ABOUT OCM

OCM Industrial Doors is an Italian company which exports worldwide and a leader in the production and installation of a wide range of industrial doors and equipment associated with them. Our company has been growing steadily over the last 70 years thanks to our ability to offer Customers the best materials and the most reliable service on the market. We offer a line of high-quality industrial doors and have developed an enviable reputation for our commercial support and responsiveness to Customers. The level of our service will exceed your expectations. We wish to offer our products by following two guidelines: the best value for money and reliability. Our broad range of products allows us to satisfy any kind of industrial, commercial and residential application. They are the best solution for any building, increasing productivity, energy efficiency and consequently affordability.



OPEN THE DOORS OF YOUR BUSINESS!



OCM_IM_FOLDUDDOORS_T2PAGINE_1023_INGL_VER01